



# CONVECTION OVEN

## MARATHONER GOLD - HALF SIZE

### ELECTRIC, SINGLE DECK

EH/10SC; EH/10CCH

#### Standard Features

- 7.5 kW high efficiency heating elements
- Available standard depth
- Single deck convection oven is 33" in height (with 4" legs)
- Patented "plug-in, plug-out" control panel - easy to service
- Stainless steel front, sides and top
- Single door with windows
- Coved, fastener-free, porcelain interior
- Soft Air, two speed, 1/3 hp, fan motor
- 11-position rack guides and 5 plated oven racks
- Electronic ignition with solid state temperature controls
- Forced cool down fan mode
- Oven "ready" light -cycles with burners



#### Available Controls

##### SC-Standard Controls

140°F to 500°F solid state thermostat and 60 minute mechanical cook timer.

##### CCH-Cycle / Cook & Hold Control

150°F to 500°F temperature controller with 140°F to 200°F "Hold" thermostat Dual digital display shows time and temperature. A fan cycle timer pulses the fan.

#### STANDARD CONSTRUCTION SPECIFICATIONS

**Exterior Finish:** Stainless steel front, top, and sides. Back is aluminized steel.

**Doors:** Single door with window. Stainless steel construction, heavy-duty welded steel frame and 5/8" diameter full-length hinge pin.

**Electrical System:** Terminal connections are located below oven section and are accessible from the front of the oven. These sheath type electrical heating elements located at the rear of the oven function as a single heating unit with a combined rating of 7.5 kW. Available voltages include 208, 240, 380, and 480 VAC single or three phase, 50/60 Hz. Ovens equipped with 480VAC single or three phase heating elements use 240V controls and motors and do not require separate electrical lead wires.

**Rack and Rack Guides:** Heavy-duty removable wire rack guides spaced on 1-5/8" centers offer 11 different rack positions. 5 wire racks provided with each oven.

**Blower Fan and Motor:** 1/2hp, 2-speed motor, 1725/1140 r.p.m

**Oven Heating:** Oven heating is regulated by an adjustable solid state thermostat control. Blower fan circulates air within the cavity "scrubbing" heat to the oven interior for even heat distribution within the cavity. Manual reset high limit temperature control protects the oven from overheat condition.

**Control Panel:** Located of front, at right side of oven, away from heat zone. Removable panel opens downward for easy servicing.

**Legs:** 4" stainless steel legs standard.

**Note:** Oven cannot be operated without fan in operation.



Models:

EH/10SC

EH/10CCH

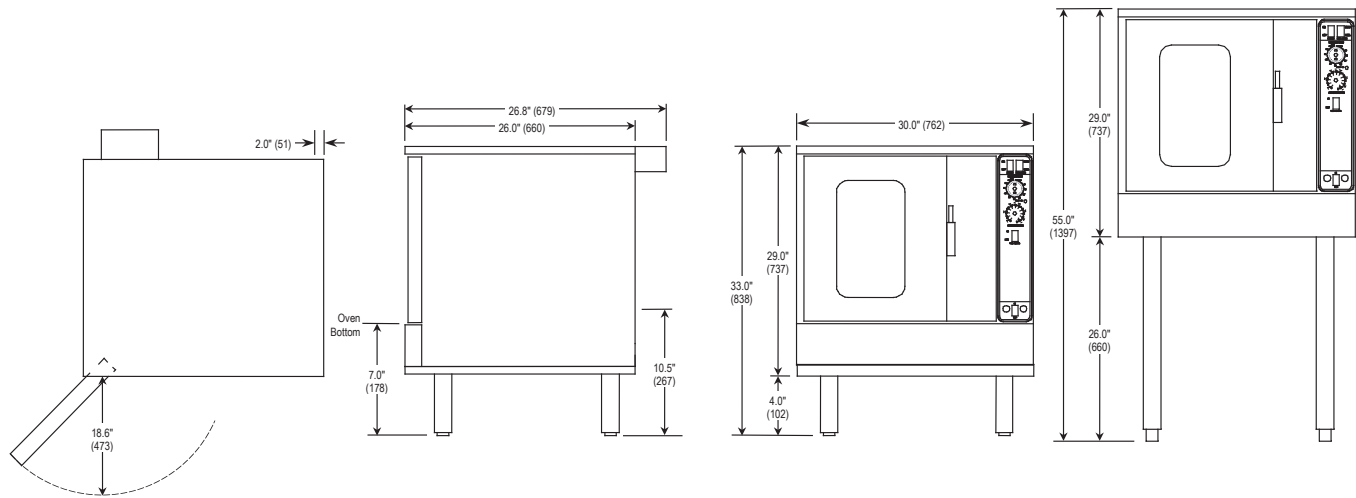

MODEL	OVEN INTERIOR			RACK CLEARANCE		SHIPPING CRATE				
	WIDTH	DEPTH	HEIGHT	WIDTH	DEPTH	WIDTH	DEPTH	HEIGHT	VOLUME	WEIGHT
EH/10	15.8" (401)	21.3" (541)	20" (508)	13" (330)	21" (533)	53" (1346)	45.5" (1157)	45" (1143)	62.8 cu. ft. (1.78 cu. m.)	420 lbs (190.5 kg.)

**Note:** When shipped on legs, crated height is 69" (1753 mm)

### UTILITY INFORMATION

**Standard:** 1/2 horsepower, 2 speed motor, 1725/1140 r. p. m.

ELECTRICAL DATA		AMPS PER LINE				
EACH OVEN	VOLTAGE	1 PHASE	3 PHASE			
			X	Y	Z	NEUT.
7.5 kW Heating Elements and Controls	208 VAC, 60Hz	36	24	24	21	0
	220/240 VAC, 50Hz	31	20	20	18	0
	240 VAC, 60Hz	33	21	21	19	0
	380/220 VAC, 50Hz	20	12	12	14	4
	415/240 VAC, 50Hz	34	11	11	12	4
	480 VAC, 60Hz	18	11	11	9	0

\* All units shipped single phase. Single phase easily converted to three phase. Add an additional 4 amps for the control panel.

### MISCELLANEOUS

- Clearances from combustibles: Top, bottom, right, left side -0".
- Recommended - install under vented hood.
- Check local codes for fire and sanitary regulations.

#### NOTICE:

Southbend has a policy of continuous product research and improvement. We reserve the right to change specifications and product design without notice. Such revisions do not entitle the buyer to corresponding changes, improvements, additions or replacements for previously purchased equipment.

### OPTIONS AND ACCESSORIES

- Stainless Steel oven interior
- Stainless Steel solid door
- 26" stainless steel legs
- 26" stainless steel legs with casters
- 26" stainless steel legs with flanged legs
- Swivel Caster - front with locks
- Knocked down packaging
- Export Crating
- Extra oven racks
- 208/240V 50/60 cycle ( for use on 1 or 3 phase)
- Down draft diverter for direct flue
- 3/4" quick disconnect with flexible hose (specify length: 3ft, 4ft, or 5ft)
- 2" air insulation panel ( stainless steel only)

**INTENDED FOR COMMERCIAL USE ONLY.  
NOT FOR HOUSEHOLD USE.**



1100 Old Honeycutt Road, Fuquay-Varina, NC 27526  
(919) 762-1000 www.southbendnc.com