



300 SERIES RESTAURANT RANGE

4 Open Burners, Single Oven

Standard Oven
324E

Standard Features

- 26,000 BTU NAT Burners (20,000 BTU LP)
- 4 patented, clog-free, cast iron burners
- Stainless steel front and shelf
- Galvanized sides
- Removable cast iron, flush-top grates
- Single-piece drip tray under burners
- Heat resistant door handle
- Commercial gas range 24" wide with a 37" cooking top (including 6" high adjustable legs)
- Hinged lower valve panel
- One year Parts and Labor Warranty

Space Saver Oven

- 32,000 BTU NAT (30,000 BTU LP)
- Single rack per oven
- Large 19-1/2" wide x 26-1/2" deep oven
- Equipped with a flame safety device
- Thermostat range from 250°- 500°F (121°-260°C) with low setting



(shown with optional casters)

Job #

STANDARD CONSTRUCTION SPECIFICATIONS

Exterior Finish: Stainless steel front and shelf standard. Galvanized sides.

Range Top: 4 -26,000 BTU NAT (20,000 BTU LP) cast iron non-clogging burners. Center-to-Center measurements between burners not less than 12", sided to side, or front to back. Removable flush-top grates are cast iron and a one-piece tray is provided under burners to catch drippings.

Back Shelf: Rigid, single deck stainless steel.

Legs: 6" black, adjustable

Space Saver Oven: 32,000 BTU NAT (30,000 BTU LP) with oven thermostat low temperature type adjustable for 250°F to 500°F. Automatic safety pilot is hydraulic type. Cavity side, top & back aluminized steel. Oven bottom & door lining porcelain enamel finish.

Rack and Rack Guides: 2 position rack guides with one removable rack.

Door: Heavy-Duty construction with extra heavy-duty hinges and quadrants. With cool tubular handle.

Pressure Regulator: Attached



Models: 324E

Dimensions -in (mm)

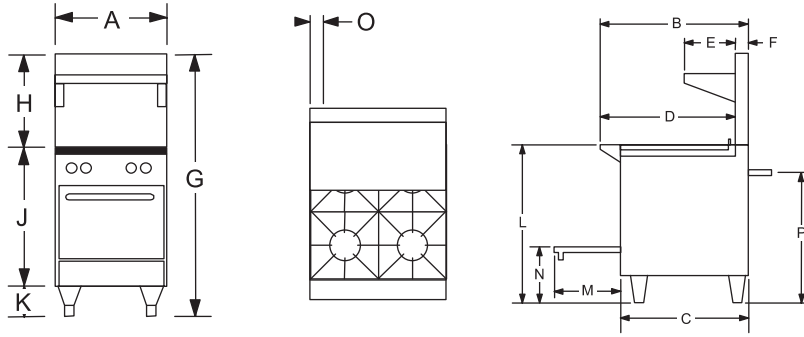

MODELS	EXTERIOR										COOK TOP	DOOR OPENING	OVEN BOTTOM	3/4" GAS CONN.	
	Width A	Depth B	C	D	E	F	G	H	J	K	L	M	N	O	P
324E	24.50" (622)	34.00" (864)	29.75" (756)	31.00" (787)	12.00" (305)	2.75" (70)	59.50" (1511)	22.50" (572)	31.00" (787)	6.00" (152)	37.00" (940)	15.50" (394)	13.00" (330)	2.50" (64)	30.25" (768)

Models	BURNERS (BTU EACH NAT/LP)			OVEN INTERIOR			CRATE SIZE			CUBIC VOLUME	CRATED WEIGHT
	GRIDDLE	OPEN	OVEN	WIDTH	DEPTH	HEIGHT	WIDTH	DEPTH	HEIGHT		
324E	-	4@(26K/20K)	1@(32K/30K)	19.50" (495)	26.50" (673)	14.00" (356)	44.00" (1118)	45.50" (1158)	48.00" (1219)	55.6 cu. ft 1.57 cu.m.	350 lbs. 158.8 kg.

UTILITY INFORMATION

Gas:

- 324E Total BTU-NAT: 136,000; LP: 110,000
- Required operating pressure:
 Natural Gas 4" W.C.
 Propane Gas 10" W.C.
- Pressure regulator is supplied with unit.
- Required supply line size to the regulator is 3/4" NPT.
- If using Flex-Hose, the I.D. should not be smaller than the I.D. of the manifold of the unit to which it is being connected
- Check local codes for fire and sanitary regulations.
- If the unit is connected directly to the outside flue, and A.G.A approved down draft diverter must be installed at the flue outlet of the oven

MISCELLANEOUS

- If using Flex-Hose, the I.D. should not be smaller than 3/4" and must comply with ANSI Z 21.69
- If casters are used with flex hose, a restraining device should be used to eliminate undue strain on the flex hose
- For installation on combustible floors (with 6" high legs) and adjacent to combustible walls, allow 6" clearance.
- Install under vented hood
- Check local codes for fire, installation and sanitary regulations.

NOTICE:

Southbend has a policy of continuous product research and improvement. We reserve the right to change specifications and product design without notice. Such revisions do not entitle the buyer to corresponding changes, improvements, additions or replacements for previously purchased equipment.

OPTIONS AND ACCESSORIES

- Casters-all swivel-front with locks Extra oven racks

**INTENDED FOR COMMERCIAL USE ONLY.
NOT FOR HOUSEHOLD USE.**



1100 Old Honeycutt Road, Fuquay-Varina, NC 27526
(919) 762-1000 www.southbendnc.com